

Perle

MANUALE DI PROGRAMMAZIONE IT

PROGRAMMING INSTRUCTIONS UK

MANUEL DE RÉGLAGE FR

MANUAL DE REGULACIÓN ES



MP2-POOL-T

DESCRIZIONE PANNELLO FRONTALE



1. Display 2 Digit, 7segmenti
2. Led **rosso**:
 - acceso fisso = segnale di enable presente
 - spento = segnale di enable non presente
 - lampeggiante = pompa in dosaggio
3. Tasto **OK/SbY**:
 - mette la pompa in stand-by
 - Salva le modifiche
4. Tasto **SET**:
 - Fa navigare all'interno del menu
 - Modifica il valore dei parametri
 - Visualizza i parametri memorizzati

FUNZIONI GENERALI DELLA POMPA :

- REGOLAZIONE DEI TEMPI DI DOSAGGIO
- REGOLAZIONE DELLA PORTATA
- RITARDO DI ACCENSIONE (fisso 30min)
- RIPRISTINO DEI PARAMETRI DI DEFAULT
- CONTROLLO DI ABILITAZIONE AL DOSAGGIO
- CONTROLLO DI LIVELLO
- STOP DEL DOSAGGIO (**STAND_BY**)
- FUNZIONE DI **PRIMING**
- FUNZIONE DI **VISUALIZZAZIONE DELLA PROGRAMMAZIONE**

REGOLAZIONI DI FABBRICA

- nA : **8 accensioni/dosaggi giornalieri**
- tA: **30 minuti (tempo totale di dosaggio giornaliero)**
- FL: **FS portata massima**
- RITARDO DI ACCENSIONE: **30 minuti (non modificabile) di attesa dopo il ricevimento del segnale di abilitazione prima di effettuare il primo dosaggio giornaliero**

Descrizione del funzionamento con i parametri di fabbrica:

Al ricevimento dell'enable (=pompa di ricircolo attiva) la pompa attende 30 minuti (ritardo di attivazione) prima di dosare. Passati questi 30 minuti la pompa doserà 8 volte (=nA) durante la giornata ad intervalli fissi di 1 ora, per 3minuti e 45 secondi (= tA : nA), alla portata massima (FL= FS). Passate 8 ore dall'inizio del dosaggio, la pompa finisce il suo ciclo di lavoro giornaliero e si mette in attesa di ricevere un nuovo segnale di abilitazione per iniziare un nuovo ciclo giornaliero, attende cioè che la pompa di ricircolo venga spenta e riaccesa.

RIPRISTINO DELLE REGOLAZIONI DELLA CASA



Premere e rilasciare contemporaneamente i tasti **OK/SbY** e **SET** . Il display mostra la scritta "r S" (reset) e la pompa automaticamente va nello stato di accensione in cui controlla l'ingresso di enable. Quando riceve l'abilitazione attende 30 minuti prima di effettuare il primo dosaggio della giornata

CONNESSIONI DELLA POMPA

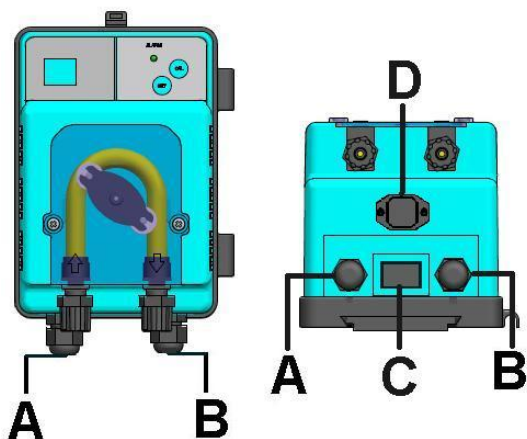

- A** - è il cavo di alimentazione elettrica , 230 V- 50Hz (a richiesta 115 ~).
- B** - è il cavo di abilitazione, 230V -50Hz , (a richiesta 115~)
- C** - è l'interruttore **Opzionale**
- D**- è il connettore per la sonda di livello **Opzionale**

STAND BY (STOP)

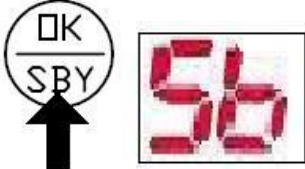
	<p>La pressione del tasto OK/STBY pone la pompa in stato di stand by:</p> <ol style="list-style-type: none">1) CESSA IL DOSAGGIO2) Il display scrive "Sb" <p>La nuova pressione del tasto OK/STBY fa tornare la pompa nello stato di funzionamento in cui era.</p>
---	---

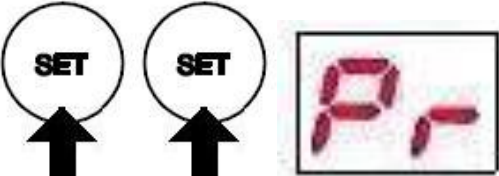

ADESCAMENTO (PRIMING)

	<p>Premere 2 volte il tasto SET per mettere la pompa in stato di Priming. In questo stato la pompa dosa alla massima portata permettendo così l'adescamento del prodotto chimico. Il display mostra la scritta Pr =Priming ovvero adescamento</p> <p>La nuova pressione del tasto SET fa tornare la pompa nello stato di funzionamento in cui era prima dell'adescamento.</p>
--	---

CONTROLLO DI LIVELLO

	<p>La chiusura del contatto di livello, libero da tensione, provoca:</p> <ol style="list-style-type: none">1) la cessazione dell'attività di dosaggio2) Il display visualizza la scritta "LE" (=LEVEL =livello) <p>La riapertura del contatto di livello fa tornare la pompa , nello stato di FUNZIONAMENTO congruente con gli ingressi attuali della pompa.</p>
--	---

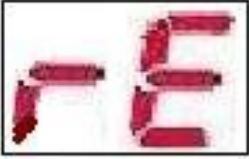
FUNZIONAMENTO

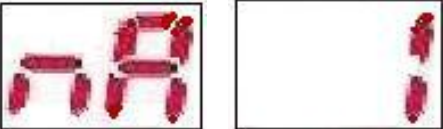
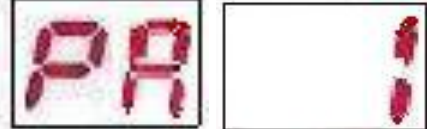
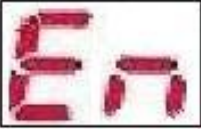
<p>STATO READY :</p>  <p>STATO DELAY :</p>  <p>STATO DI DOSAGGIO :</p>  <p>STATO DI PAUSA :</p>  <p>STATO DI END</p> 	<p>All'accensione la pompa si mette nello stato di "ready" in cui :</p> <ul style="list-style-type: none">-visualizza : rE-controlla l'ingresso di enable <p>In questo stato si può effettuare l'adescamento e la programmazione dei parametri.</p> <p>Nel momento in cui la pompa riceve il segnale di enable, la pompa passa nello stato di "delay" ovvero ritardo.,</p> <p>In questo stato la pompa:</p> <ul style="list-style-type: none">-visualizza : dE-attende 30 minuti prima di passare alla fase di dosaggio. <p>La pompa controlla costantemente la presenza del segnale di enable. Nel caso in cui questo dovesse mancare, la pompa torna nello stato di READY altrimenti, passati i 30 minuti, la pompa passa nello stato di dosaggio.</p> <p>In questo stato la pompa:</p> <ul style="list-style-type: none">-dosa alla velocità programmata in FL e per il tempo calcolato dal microprocessore: tA/nA.-visualizza alternativamente la scritta nA (= numero di Attivazione) che si alterna con 1 ovvero prima attivazione/dosaggio della giornata.- il led rosso lampeggia indicando il dosaggio <p>Finito il dosaggio la pompa passa nello stato di Pausa.</p> <p>In questo stato la pompa:</p> <ul style="list-style-type: none">-non dosa ed attende che passi 1 ora dall'inizio del primo dosaggio per effettuare il secondo-visualizza alternativamente la scritta PA (= Pausa di Attivazione) che si alterna con 1 ovvero prima Pausa della giornata.- il led rosso è fisso indicando la presenza del segnale di enable. <p>Passata la pausa la pompa passa nello stato di dosaggio: 2° dosaggio della giornata.</p> <p>Finiti i dosaggi e le pause programmate la pompa passa nello stato di End nel quale la pompa attende che il segnale di enable venga spento.</p> <p>Nel momento in cui questo avviene, la pompa torna nello stato di READY ed è pronta a ricevere di nuovo il segnale di enable per cominciare il nuovo ciclo giornaliero.</p>
--	--

STRUTTURA DEL MENU

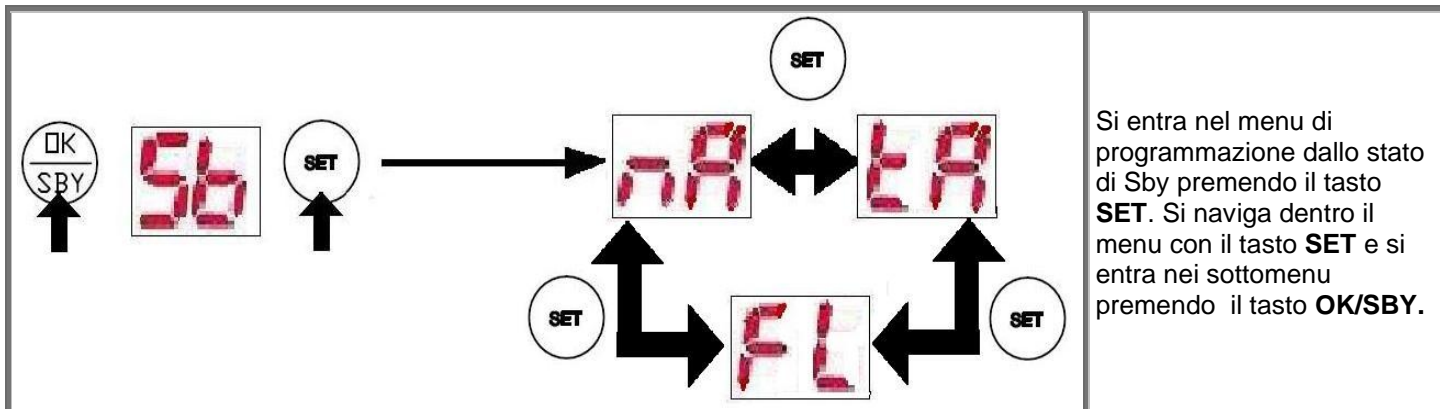

PROGRAMMAZIONE DEL FUNZIONAMENTO

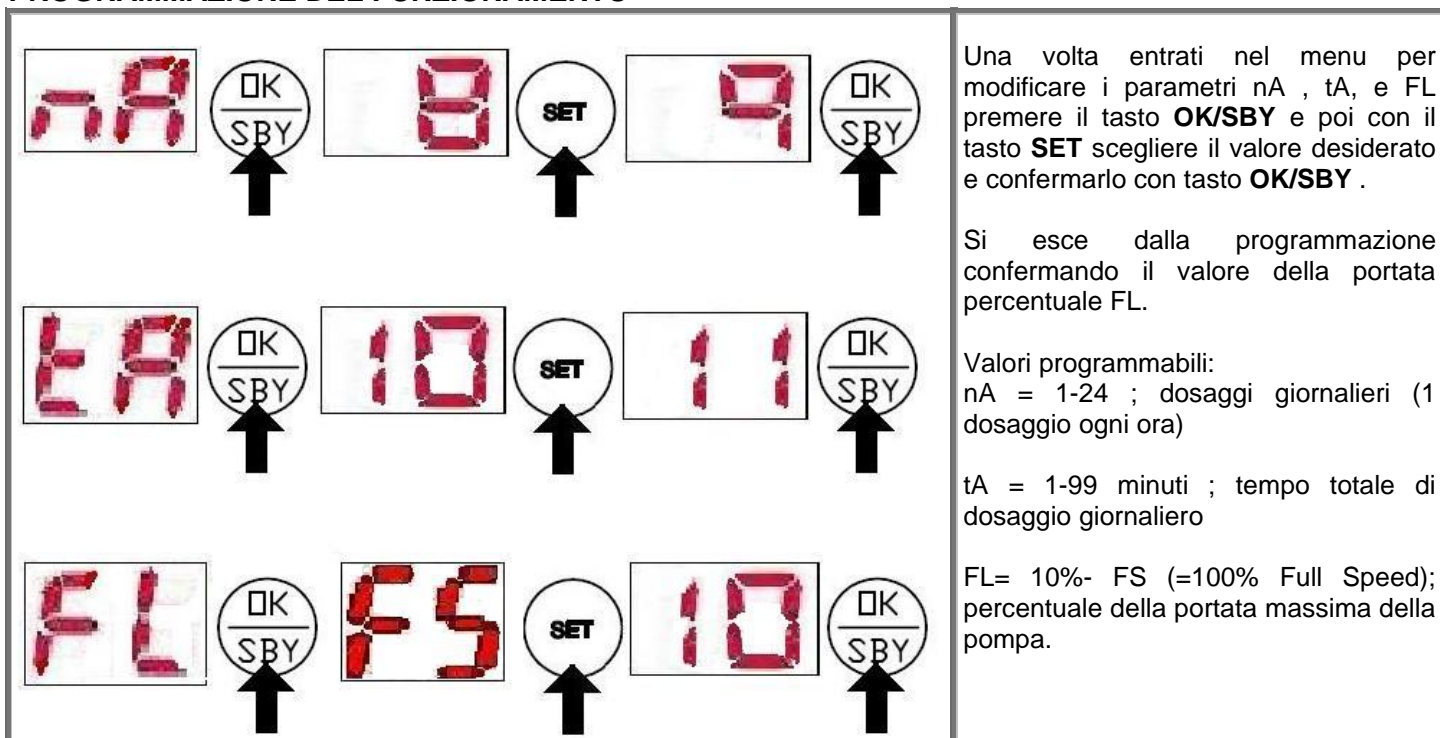

VISUALIZZAZIONE DELLE PROGRAMMAZIONI

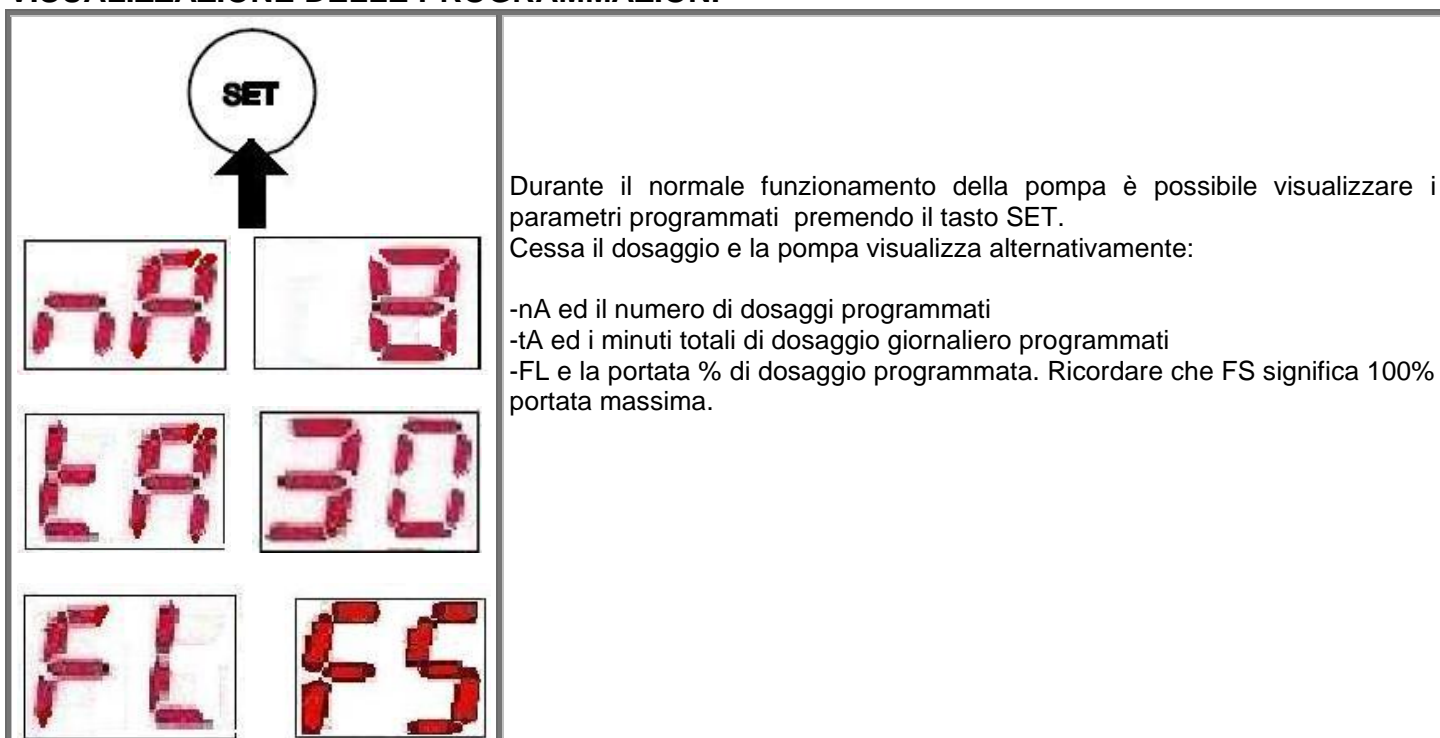

FRONTAL PANEL DESCRIPTION

	<p>1. Display: 2 digit , 7 segments</p> <p>2.Red Led:</p> <ul style="list-style-type: none"> ▪ fix lighted = enable input is ON ▪ switched off = enable input is OFF ▪ blinking = pump is dosing <p>3. OK/SbY button:</p> <ul style="list-style-type: none"> ▪ puts the pump in stand_by mode ▪ saves the changes <p>4. SET button:</p> <ul style="list-style-type: none"> ▪ allows to navigate through the menu ▪ Modifies the parameters values ▪ Visualies the parameters values
---	--

<p>GENERAL FUNCTIONS OF THE PUMP :</p> <ul style="list-style-type: none"> - DOSING TIME REGULATION - FLOW RATE REGULATION - START UP DELAY (30 minutes , unmodifiable) - DEFAULT PARAMETER RESTORING - DOSING ENABLE CONTROL - LEVEL CONTROL - STOP DOSING (STAND_BY) - PRIMING FUNCTION - FUNCTION FOR THE VISUALIZATION OF THE PROGRAMMED PARAMETERS

DEFAULT SETTINGS

<ul style="list-style-type: none"> • nA : 8 daily dosing • tA: 30 minutes (total daily dosing time) • FL: FS maximum pump flow rate • START UP DELAY: 30 minutes (unmodifiable), this is the time that the pump waits, after the receiving of the enable input signal, before beginning the first daily dosing.

<p>Description of the default pump functioning:</p> <p>After the receiving of the enable input (recirculation pump is switched on) , the pump waits 30 minutes (delay start) before the first daily dosing. The pump will dose 8 times (=nA) during the day with fixed intervals of time of 1 hour. Each dosing will be of 3 minutes and 45 seconds (=tA : nA), at the maximum flow rate (FL=FS). After 8 hours from the first dosing the pump ends the daily cicle and waits for a new enable signal input.</p>

DEFAULT SETTINGS RESTORE

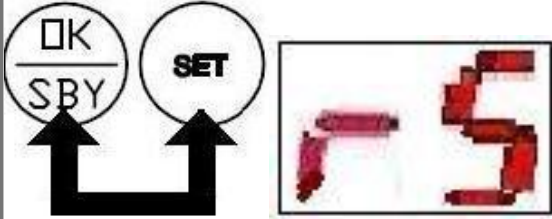
	<p>Push and release together OK/SbY and SET buttons.</p> <p>The display will show "r S" (reset) and all the default parameters are restored in memory. The pump will go in the Ready state during which it waits for the enable input. All the default settings are restored in memory. After the receiving of the enable input (recirculation pump is switched on) , the pump waits 30 minutes (delay start) before the first daily dosing.</p>
--	--

PUMP'S CONNECTIONS

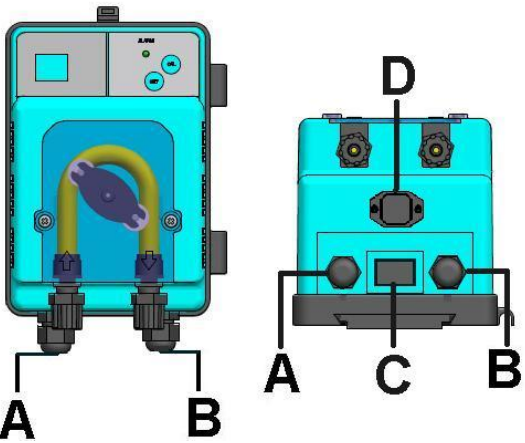
	<p>A – Power cable, 230 V- 50Hz (upon request : 115 ~)</p> <p>B – Enable input cable, 230 V- 50Hz (upon request : 115 ~)</p> <p>C – ON-OFF switch OPTIONAL</p> <p>D - Level probe connector (3 and 4 contacts). OPTIONAL</p>
---	--

STAND BY (STOP)

	<p>Push the button OK/SBY to put the pump in stand by:</p> <ol style="list-style-type: none"> 3) STOP DOSING 4) The display shows “Sb” <p>Push again OK/SBY to put again the pump in the state in which it was before the stand by.</p>
---	--

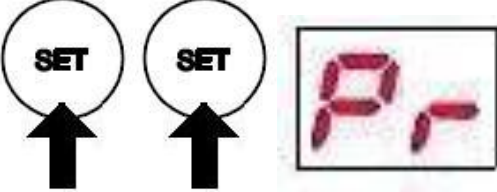

PRIMING

	<p>Press the SET key twice to put the pump in state of priming. In this state, the pump doses at maximum flow allowing priming of the chemical. The display shows Pr = priming. Press again SET button to put the pump in the operating state it was before the priming.</p>
--	---

LEVEL CONTROL

	<p>The closing of the level input contact, free of tension, while the pump is working, will cause:</p> <ol style="list-style-type: none"> 1) the dosing stops 2) the display shows “LE” (=LEVEL) <p>When the level contact gets opened again, the pump returns to working mode compatible with the actual inputs.</p>
--	--

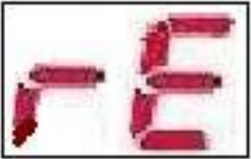
FUNCTIONING

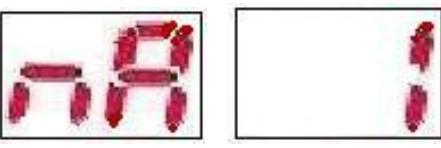
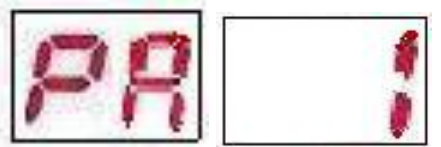
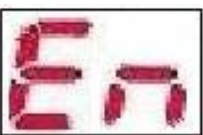
<p>READY STATE :</p>  <p>DELAY STATE :</p>  <p>DOSING STATE :</p>  <p>PAUSE STATE :</p>  <p>END STATE</p> 	<p>When the pump switched on it goes in the " ready" state in which :</p> <ul style="list-style-type: none"> - the display shows: rE - the pump controls the enable input <p>In this state, it can perform the priming and the programming . In the moment in which the pump receives the enable signal, the pump passes in the state of " delay" .</p> <p>In delay state :</p> <ul style="list-style-type: none"> - the displayshows: dE - the pump waits 30 minutes before moving to the dosing phase . <p>The pump continuously checks the presence of the enable signal . In the case where this is missing, the pump returns to the READY state otherwise, after 30 minutes, the pump starts dosing.</p> <p>During dosing state :</p> <ul style="list-style-type: none"> - the pump doses at the flow rate programmed in FL and for the time calculated by the microprocessor : tA : nA . - the display shows the message nA (= number of activation) alternating with 1 (= first activation / dosing of the day). - The red LED flashes indicating the dosing <p>After the dosing pump goes in Pause state.</p> <p>In this state the pump :</p> <ul style="list-style-type: none"> - does not dose and waits 1 hour from the first dosing to do the next one. - the display shows the word PA (= Pause) alternating with 1 (= first pause of the day). - The red LED is fix lighted , indicating the presence of the enable signal . <p>After the Pause state the pump goes into dosage again : 2nd dose of the day.</p> <p>When the pump finishes all the dosing of the day it goes in End state. In this state the pump waits until the enable signal is switched off. At this moment , the pump returns to the READY state and is ready again to receive the enable signal to begin the new daily cycle .</p>
--	--

MENU STRUCTURE

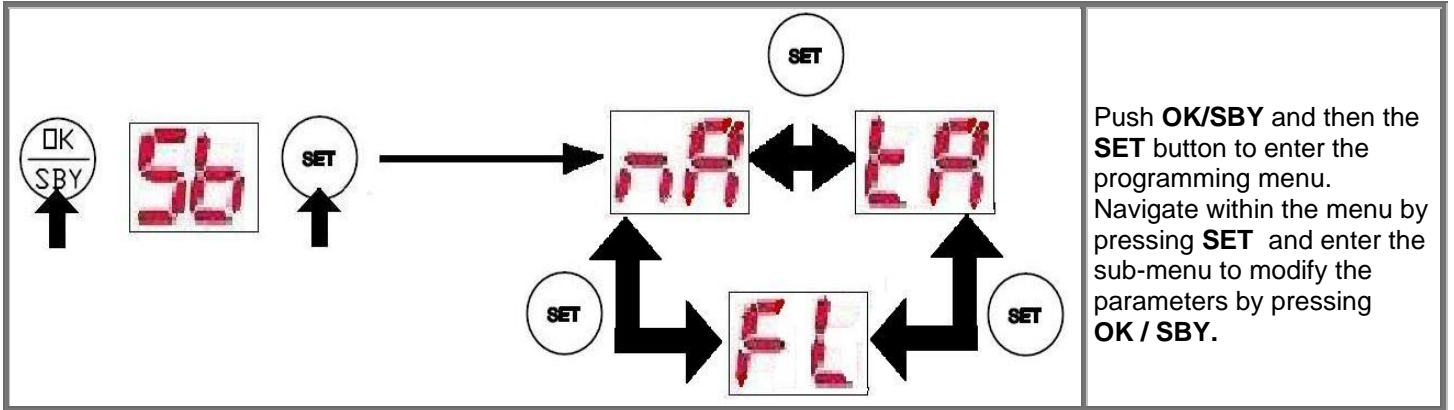

PROGRAMMING THE PARAMETERS

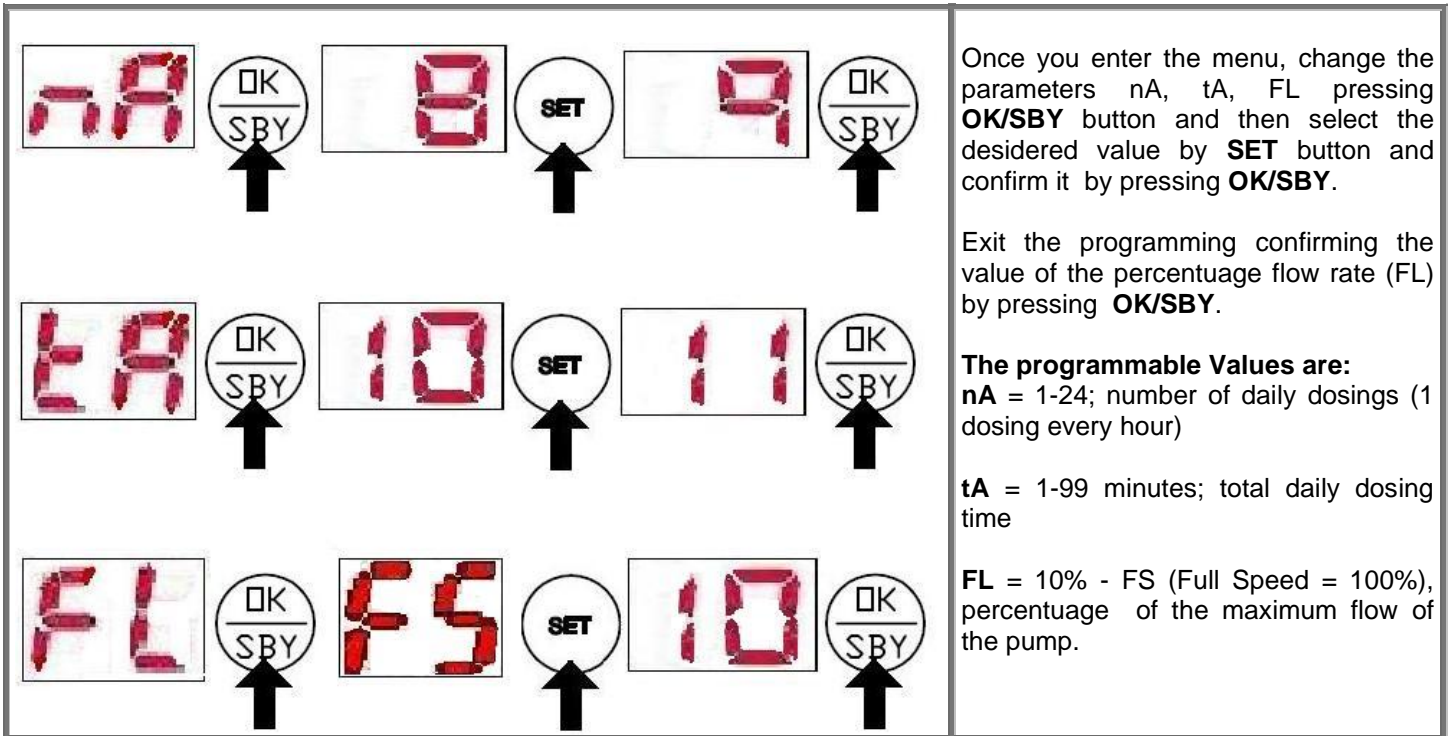

DISPLAYING THE PROGRAMMED PARAMETERS

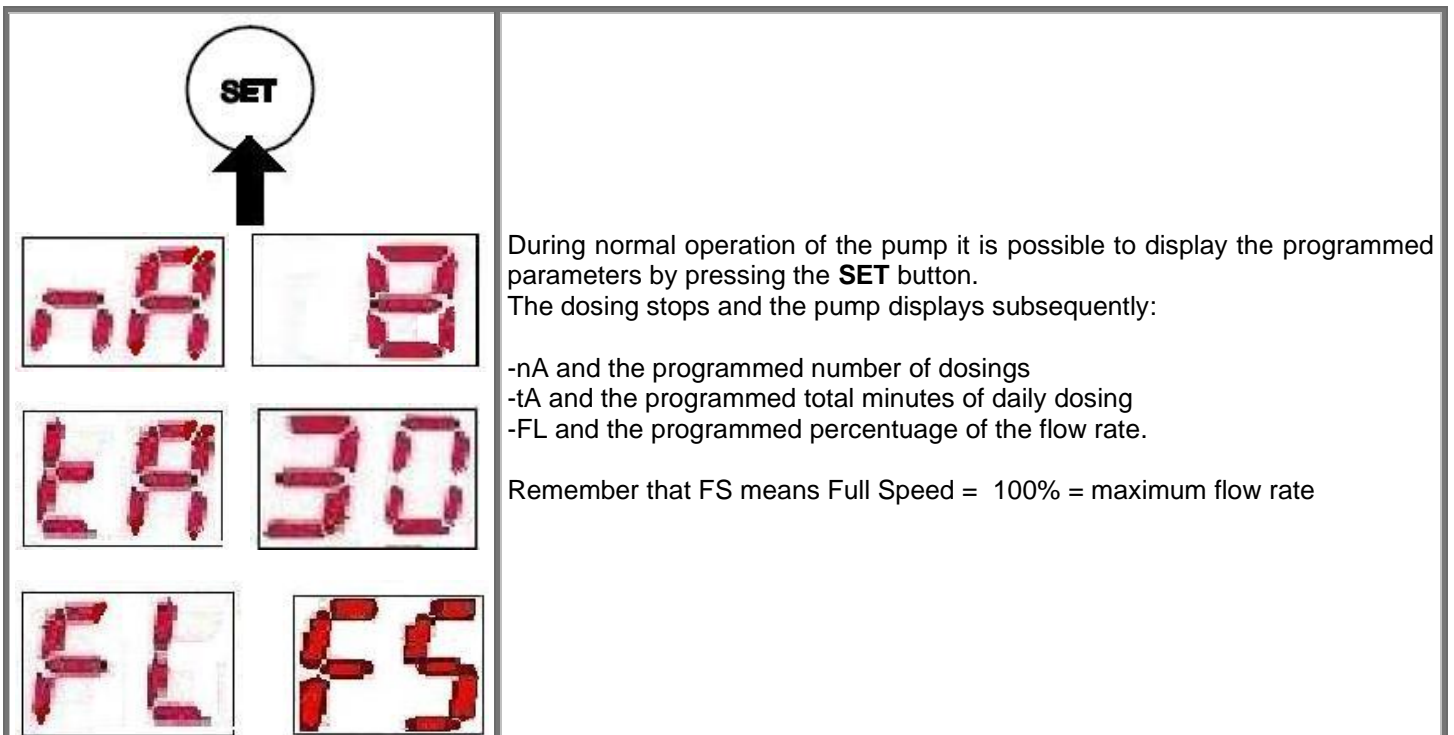

DESCRIPTION DE LA PLAQUE FRONTALE



1. Afficheur à 2 chiffres, 7 segments
2. Led rouge:
 - **allumé fixe** = signal de consentement au dosage c'est présent
 - **Off** = signal de consentement au dosage n'est pas présent
 - **Clignotant** = indique les injections
3. Touche **OK/SBY**:
 - met la pompe en stand-by
 - pour confirmer le choix
4. Touche **SET**:
 - pour naviguer dans le menu
 - Modifiez la valeur des paramètres
 - Affiche la valeur des paramètres

CARACTÉRISTIQUES GÉNÉRALES DE LA POMPE:

- REGLAGE DES TEMPS DE DOSAGE
- REGLAGE DU DÉBIT DE LA POMPE
- DÉMARRAGE TARDIF (30 minutes fixe)
- RETABLISSEMENT DES PARAMETRES DE DÉFAULT
- CONTRÔLE DU CONSENTEMENT AU DOSAGE
- CONTRÔLE DE NIVEAU
- STOP DOSAGE (**STAND_BY**)
- FONCTION D'AMORÇAGE
- FONCTION D'AFFICHAGE DES PARAMETRES PROGRAMMÉS

REGLAGE D'USINE

- nA: 8 allumages / doses journalières
- tA: 30 minutes (dosage quotidienne totale)
- FL: FS débit maximale
- RETARD DE ALLUMAGE: 30 minutes (non modifiable) à attendre après la réception du signal de consentement avant la première dose quotidienne

Description de l'opération avec les paramètres d'usine:

Dès réception du consentement (= pompe de circulation actif), la pompe attend 30 minutes (retard de allumage) avant le dosage. Passé ces 30 minutes, la pompe va doser 8 fois (= nA) au cours de la journée à intervalles fixes de 1 heure par 3 minutes et 45 secondes (= tA: nA), au débit maximale (FL = FS). Passé huit heures à partir du début du traitement, la pompe termine son cycle de travail quotidien et attend de recevoir un nouveau signal de consentement pour commencer un nouveau cycle quotidien, c'est à dire il va attendre à ce que la pompe de circulation est désactivé et activé.

RETABLISSEMENT DE RÉGLAGE D'USINE

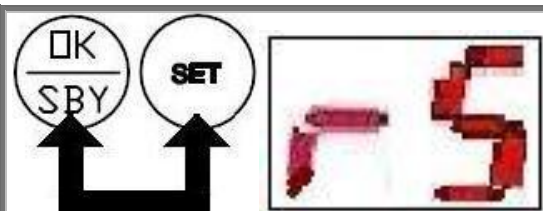

Appuyez simultanément sur la touche **OK / SbY** et **SET**.
L'écran affiche "r S" (reset) et la pompe se met automatiquement en état qui contrôle l'entrée de consentement. Quand il reçoit attend 30 minutes avant de prendre la première dose de la journée

CONNEXIONS DE LA POMPE

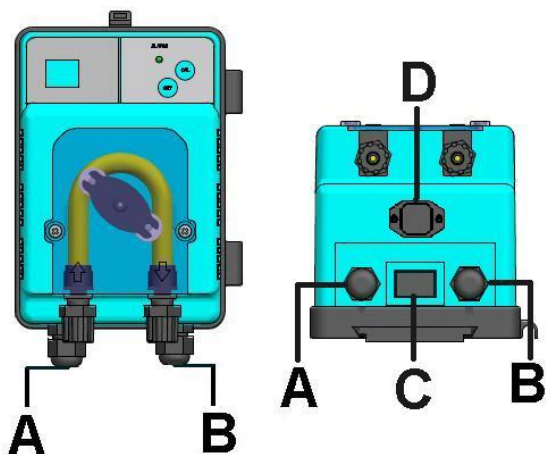

- A - Alimentation électrique, 230V-50 Hz (sur demande : 115 ~)
- B - est le câble du consentement au dosage, 230V-50 Hz (sur demande : 115 ~)
- C - Interrupteur ON_OFF. **OPTION**
- D - Connecteur de la sonde de niveau (contacts 3 et 4). **OPTION**

STAND BY (STOP)

	<p>La pression de la touche OK/STBY pendant le fonctionnement met la pompe en état de stand by:</p> <ol style="list-style-type: none">1) CESSE LE DOSAGE2) l'affichage indique « Sb » <p>La nouvelle pression de la touche OK/STBY fait revenir la pompe dans l'état de fonctionnement.</p>
--	--



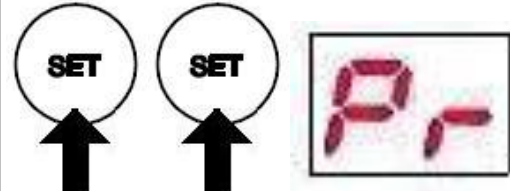

AMORÇAGE (PRIMING)

	<p>Appuyez sur la touche SET deux fois pour mettre la pompe dans un état de l'amorçage.</p> <p>Dans cet état, les doses de la pompe à débit maximal permettant ainsi l'amorçage de la substance chimique. L'affichage indique Pr =Priming =amorçage</p> <p>La nouvelle pression du SET renvoie la pompe dans l'état où il se trouvait avant l' amorçage.</p>
--	---

CONTRÔLE DU FIN NIVEAU (OPTION)

	<p>La fermeture du contact de niveau, libre de tension, pendant le fonctionnement de la pompe provoque:</p> <ol style="list-style-type: none">1) la cessation de l'activité de dosage2) le display visualise l'inscription "LE" (=LEVEL=NIVEAU) (voir la figure à coté). La rentrée du contact de niveau fait revenir la pompe dans l'état de FONCTIONNEMENT congruent avec les entrées actuelles de la pompe.
--	--

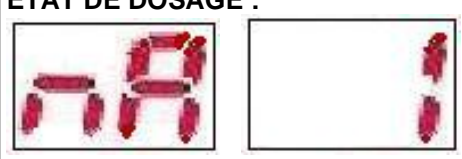
FONCTIONNEMENT

<p>ÉTAT READY :</p>  <p>ÉTAT RETARD (DELAY) :</p>  <p>ÉTAT DE DOSAGE :</p>  <p>ÉTAT DE PAUSE :</p>  <p>ÉTAT DE END</p> 	<p>Après l'allumage la pompe est placée dans le état "READY" dans laquelle:</p> <ul style="list-style-type: none">- Affiche : rE (=ready)- Contrôle à l'entrée de consentement au dosage <p>Dans cet état, vous pouvez effectuer la programmation des paramètres et l'amorçage .</p> <p>Au moment où la pompe reçoit le signal de consentement au dosage , la pompe passe à l'état de retard (delay).</p> <p>Dans cet état la pompe :</p> <ul style="list-style-type: none">- Affiche : dE- Attend 30 minutes avant de passer à la phase de dosage . <p>La pompe surveille en permanence la présence du signal de consentement . Dans le cas où ce manque, la pompe retourne à l'état READY, autrement , après 30 minutes , la pompe se met en dosage .</p> <p>Dans cet état de dosage la pompe :</p> <ul style="list-style-type: none">- Dose à la debit programmée en FL et pour le temps calculé par le microprocesseur : tA / nA .- affiche le message nA (= nombre d' activation) en alternance avec une (première activation / dose de la journée).- Le led rouge clignote pour indiquer la dosage <p>Après le dosage, la pompe se met en pause .</p> <p>Dans cet état la pompe :</p> <ul style="list-style-type: none">- elle ne fonctionne pas et elle attend 1 heure au début de le premier dosage pour effectuer le deuxième dosage.- elle affiche alternativement (PA = Pause de Activation) en alternance avec 1, c'est à dire avant la première pause de la journée.-LED rouge fixée indique la présence du signal d'activation <p>Après la pause, la pompe se met en dosage: 2ème dose de la journée</p> <p>Fini les dosages et les pauses, la pompe se met en etat de END dans lequel la pompe attend que le signal d'activation est éteint. Lorsque cela arrive, la pompe retourne à l'état READY et est prêt à recevoir à nouveau le signal d'activation pour lancer le nouveau cycle journalier.</p>
---	---

STRUCTURE DE MENU

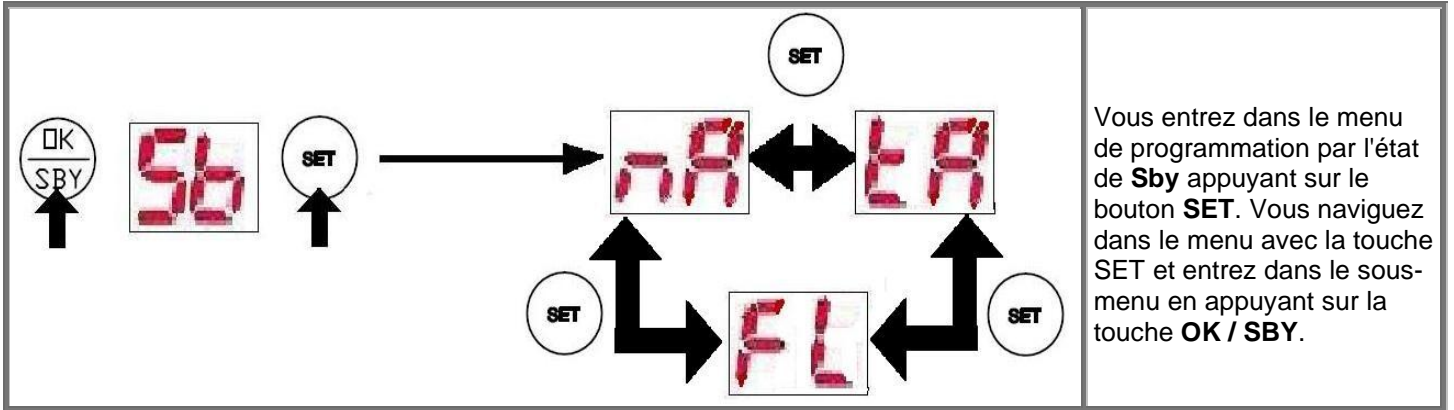

PROGRAMMATION DU FONCTIONNEMENT

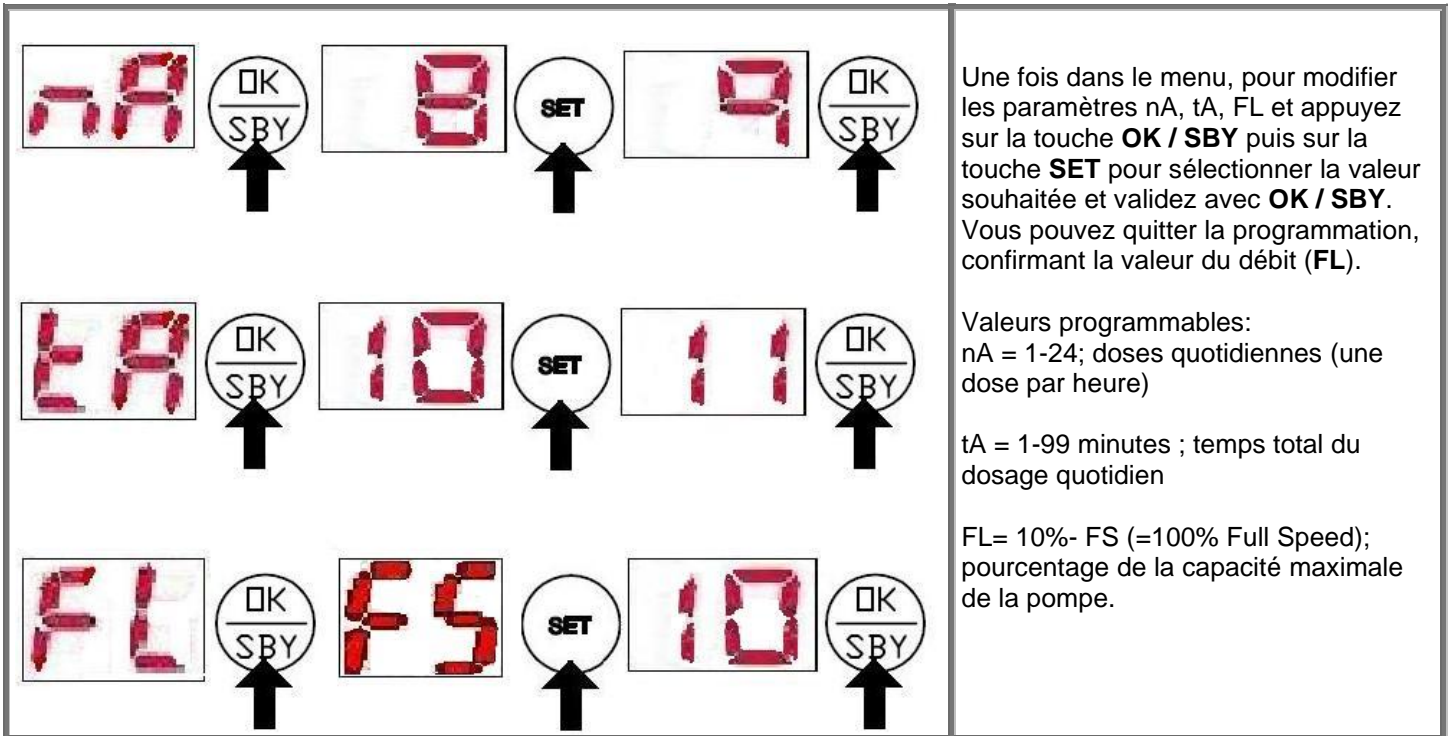

VISUALISATION DES PROGRAMMATIONS

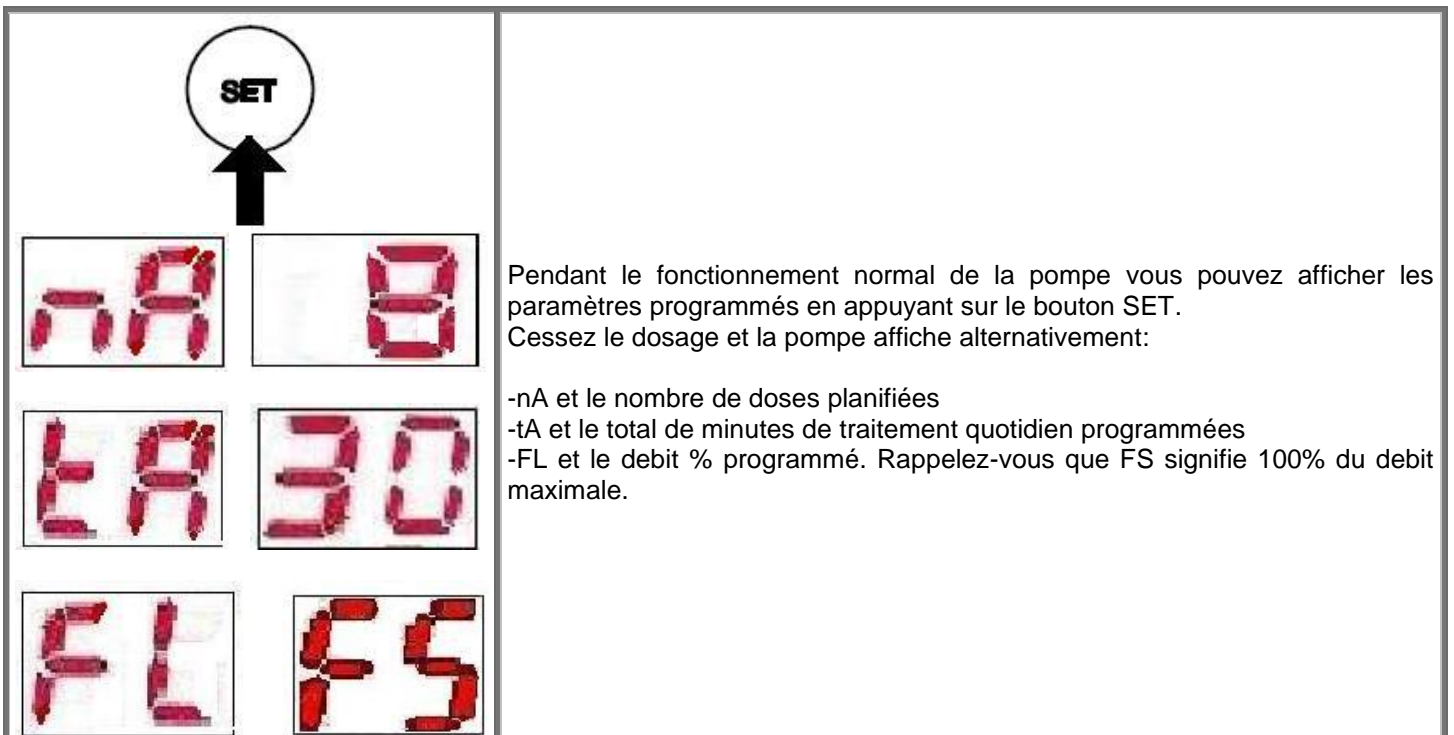

DESCRIPCIÓN DEL PANEL FRONTAL



1. Display 2 dígitos, 7 segmentos
2. LED rojo:
 - encendido =señal de habilitación presente
 - off = señal de habilitación no está presente
 - Intermitente = la bomba dosifica
3. Tecla **OK/SBY**:
 - pone la bomba en stand-by
 - Salva los cambios
 - Visualiza la programación

FUNCIONES GENERALES DE LA BOMBA:

- AJUSTE DE LOS TIEMPOS DE DOSAJE
- AJUSTE DEL CAUDAL
- INICIO TARDÍO (30 minutos fijo)
- RESTAURACIÓN VALORES DE FÁBRICA
- CONTROL DE HABILITACIÓN DE DOSAJE
- CONTROL DE NIVEL
- STOP DE DOSIFICACIÓN (STAND BY)
- FUNCIONES DE CEBADO
- FUNCIONES DE VISUALIZACIÓN DE LA PROGRAMACIÓN

VALORES DE FÁBRICA

- nA: 8 dosis diarias
- tA: 30 minutos (dosis diaria total)
- FL: FS caudal máximo
- INICIO TARDÍO: 30 minutos (no editable) para esperar después de recibir la señal de habilitación antes de la primera dosis diaria

Descripción de la operación con los parámetros de fábrica:

Una vez recibido el signal de habilitación de dosaje (= bomba de circulación encendida) la bomba espera 30 minutos (retardo de activación/ inicio tardío) antes de dosificar. Pasado estos 30 minutos, la bomba dosificará 8 veces (= nA) durante el día a intervalos fijos de 1 hora, el dosaje durará 3 minutos y 45 segundos (= tA: NA), con el caudal máximo (FL = FS). Transcurridas 8 horas después del inicio de la dosificación, la bomba termina su ciclo de trabajo diario y la espera para recibir una señal de habilitación para iniciar un nuevo ciclo diario, es decir, espera que la bomba de circulación se apaga y se enciende de nuevo.

RESTAURACIÓN VALORES DE FÁBRICA

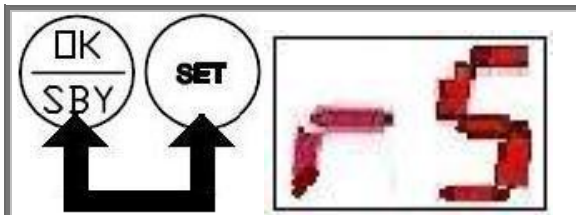

Simultáneamente presione y suelte el botón **OK/SBY** y **SET**. La pantalla muestra "rS" (reset) y la bomba entra automáticamente en stato de READY en el que controla la entrada de enable. Cuando recibe la habilitación espera 30 minutos antes de hacier la primera dosis del día

LAS CONEXIONES DE LA BOMBA

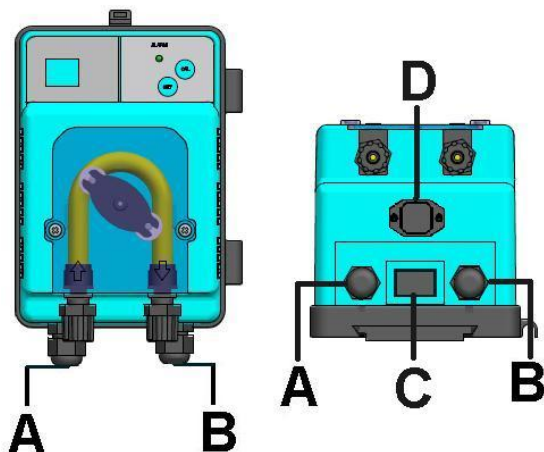

- A - cable de alimentación eléctrica de 230V-50Hz (a petición: 115 ~)
- B - cable de habilitación, 230V-50Hz (a petición: 115 ~)
- C - on_off interruptor. **OPCIONAL**
- D - conector de la sonda de nivel (contactos 3 y 4). **OPCIONAL**

STAND BY (STOP)

	<p>Pulse el botón OK/SBY y la bomba se pone en estado de stand by:</p> <ol style="list-style-type: none">5) DEJA LA DOSIFICACIÓN6) el display visualiza "Sb" <p>Al pulsar de nuevo el OK/SBY la bomba vuelve nel estado operativo en el que estaba</p>
--	---



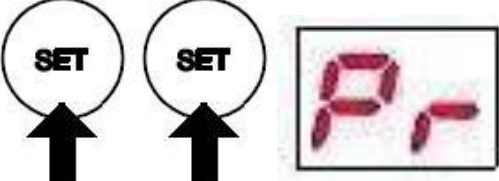

CEBADO (PRIMING)

	<p>Pulse la tecla SET dos veces para poner la bomba en estado de cebado.</p> <p>En este estado, la bomba dosifica con un caudal máximo permitiendo así el cebado de la sustancia química. La pantalla muestra Pr = Priming o cebado.</p> <p>Al pulsar de nuevo el botón SET, la bomba vuelve en estado operativo en que se encontraba antes del cebado.</p>
--	--

CONTROL DE NIVEL

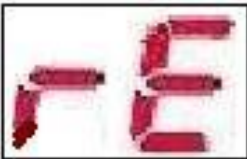
	<p>El cierre del contacto de nivel, libre de tensión, durante el funcionamiento de la bomba, en cualquiera modalidades ella se encuentra, provoca:</p> <ol style="list-style-type: none">1) el cese de la actividad de dosificación3) en el display aparece la inscripción "LE" (=LEVEL=NIVEL). <p>La reapertura del contacto de nivel hace volver la bomba en el estado de FUNCIONAMIENTO congruente con las entradas actuales de la bomba.</p>
--	--

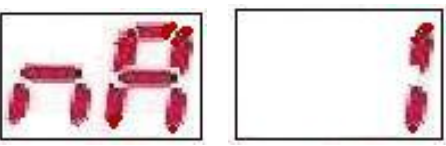
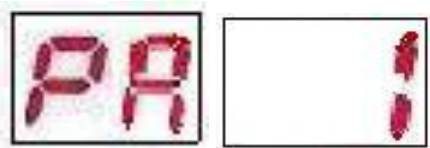
FUNCIONAMIENTO

<p>ESTADO READY :</p>  <p>ESTADO DELAY :</p>  <p>ESTADO DOSAJE :</p>  <p>ESTADO PAUSA :</p>  <p>ESTADO END</p> 	<p>Quando se activa la bomba se pone en el estado de READY en el que:</p> <ul style="list-style-type: none">- Muestra : rE- Controla la entrada de habilitación <p>En este estado , puede modificar los parámetros y puede hacer el cebado. En el momento en el que la bomba recibe la señal de habilitación , la bomba pasa en el estado de " DELAY " o retraso.</p> <p>En este estado la bomba :</p> <ul style="list-style-type: none">- Muestra : dE- Espera 30 minutos antes de pasar a la fase de dosificación . <p>La bomba supervisa continuamente la presencia de la señal de habilitación . En el caso de que este no se encuentra, la bomba devuelve al estado READY de lo contrario , después de 30 minutos , la bomba entra en la dosis.</p> <p>En este estado la bomba :</p> <p>Dosa al caudal programado en FL y por el tiempo calculado por el microprocesador : tA / nA .</p> <ul style="list-style-type: none">- Alternativamente muestra el mensaje de nA (= número de activación) alternando con 1 o primera activación / dosis del día .- El led rojo parpadea para indicar la dosis <p>Después la bomba entra en Pausa.</p> <p>En este estado la bomba :</p> <ul style="list-style-type: none">- No trabaja y espera 1 hora del inicio de la primera dosis a la segunda- muestra la palabra PA(= Pausa) alternando con 1 o primer descanso del día.- El led rojo es fijo , lo que indica la presencia de la señal de habilitación . <p>Después del descanso la bomba entra en la dosis : 2ª dosis del día .</p> <p>Atrás han quedado las dosis y descansos programados la bomba va en estado de End.</p> <p>En qué la bomba espera la señal de habilitación se apaga .</p> <p>En el momento que esto sucede , la bomba devuelve al estado READY y está lista para recibir de nuevo la señal de habilitación para comenzar el nuevo ciclo diario</p>
--	---

ESTRUCTURA DEL MENU

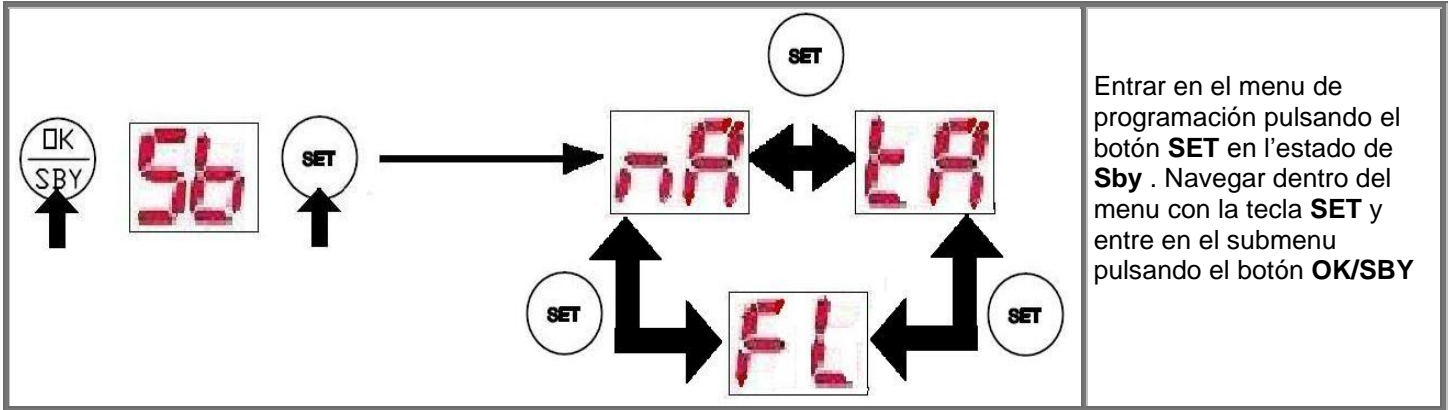

PROGRAMACIÓN DE LA OPERACIÓN

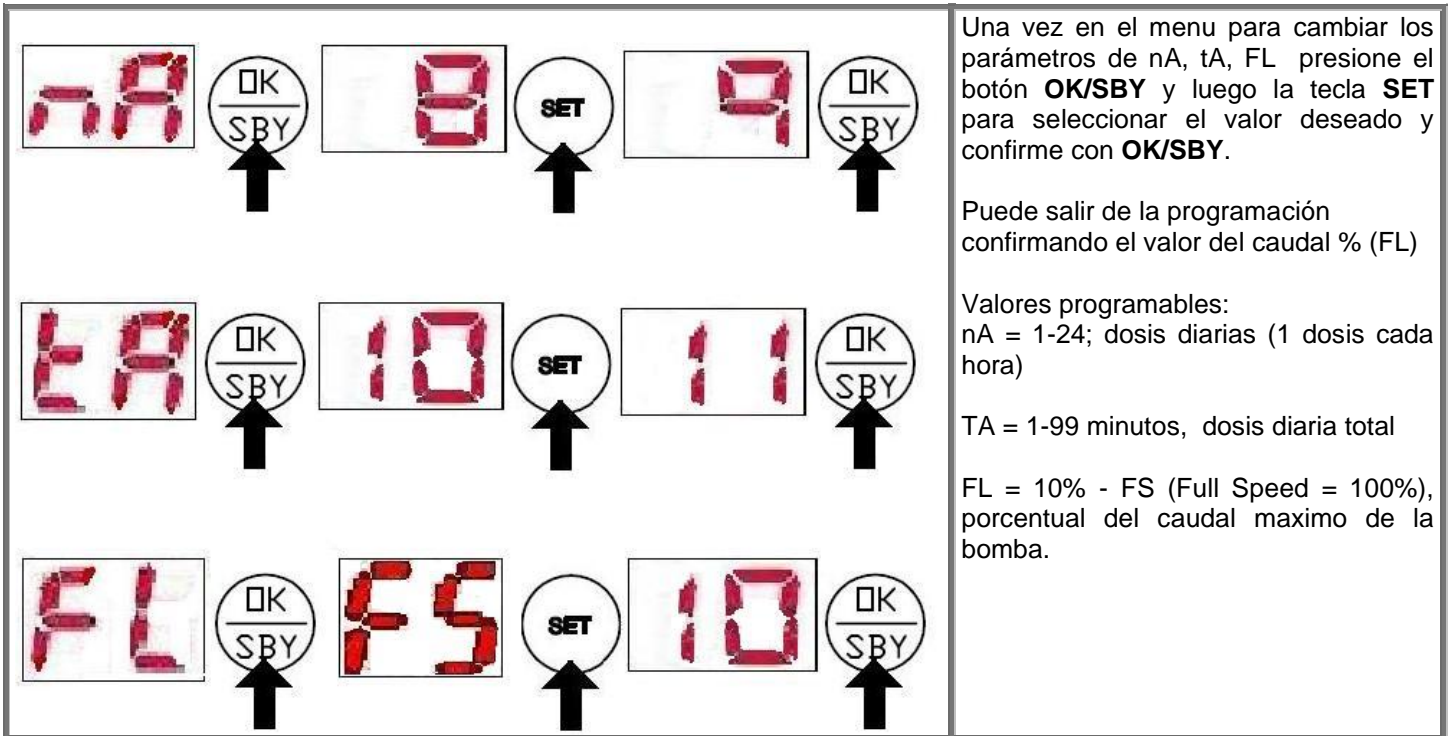

VISUALIZACIÓN DE PROGRAMACIÓN

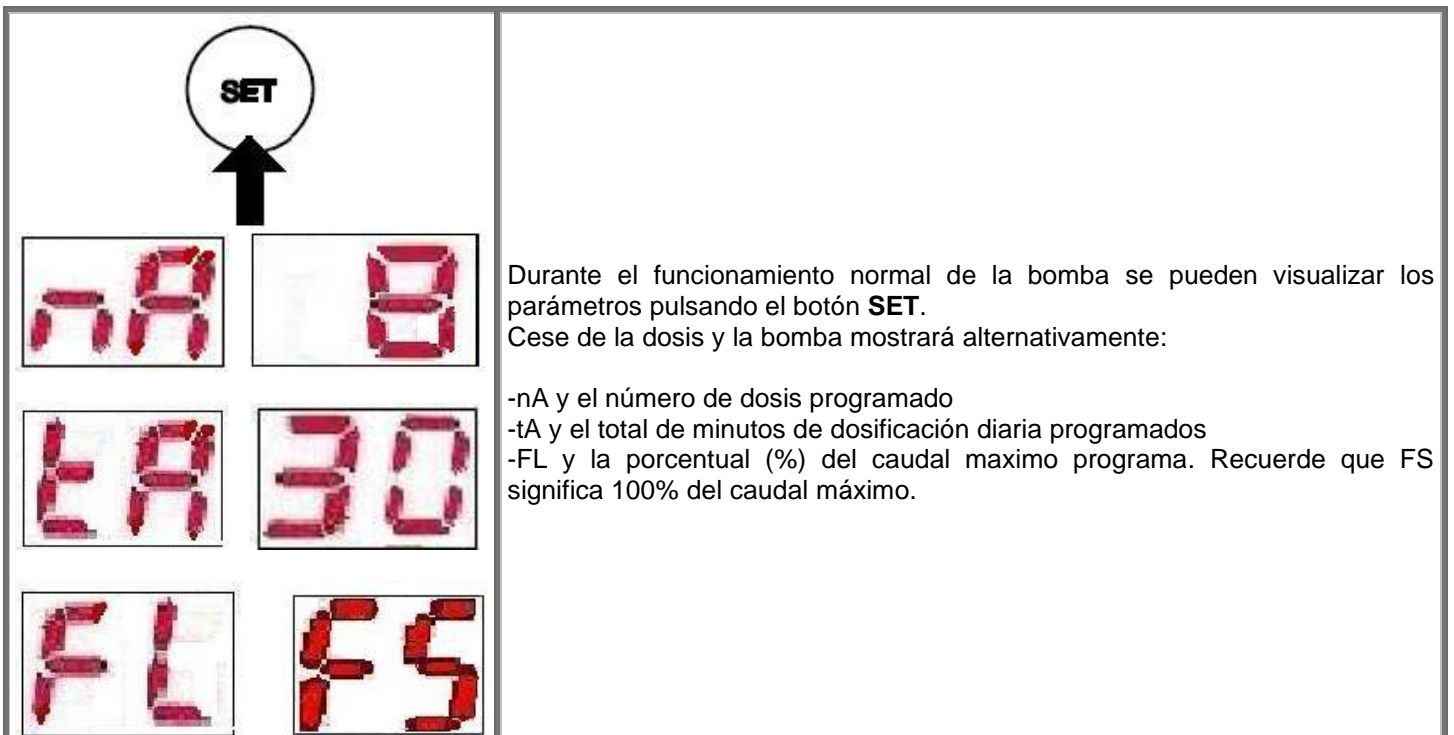

Lined writing area consisting of numerous horizontal lines for text entry.

